

# ROBX3115DSL

Offline oil filtration



# Oil cleaning: A simple solution for an invisible problem

A simple, environmentally friendly solution for increased uptime and process availability. Investing in oil cleaning gives your company a better economy.

## ROBX3115DSL – Offline oil filtration

### Removes all types of contamination:

- soft and hard particles down to nano-size
- bacteria
- water (free, bound and emulsified)
- sludge and insolubles (e.g. varnish)
- soluble oxidation products (i.e. pre-varnish)

### Benefits:

- cost-effective maintenance
- no oil changes = environmentally friendly
- change filters instead of changing oil
- increased machine lifetime
- less downtime
- no oxidation in oil



## Technical specification

### ROBX3115DSL

<b>Dry weight:</b>	33 kg
<b>Operating weight:</b>	42 kg
<b>Depth:</b>	290 mm (550 mm including legs footprint)
<b>Width:</b>	560 mm
<b>Height:</b>	850 mm (including legs) (+250mm for service height)
<b>Oil temperature:</b>	Max. 80 °C (In case of higher temperatures contact RecondOil)
<b>Working pressure:</b>	0.8–5 bar
<b>Pressure:</b>	Max. 5 bar, relief valve opens at 5 bar
<b>Power consumption:</b>	0.01–0.17 kW (variable speed)
<b>Power supply:</b>	80–230 VAC
<b>Hose connection IN:</b>	1/2" BSP
<b>Hose connection OUT:</b>	1/2" BSP
<b>Installation (see drawing):</b>	Connect as an offline unit. «IN» = hose to tank and «OUT» = hose to tank
<b>Filter insert:</b>	SKF RecondOil DST-activated depth filter (ROBX500DST) or Standard depth filter (ROBX500HY)

## Technical drawing

Figure 1

### Offline installation

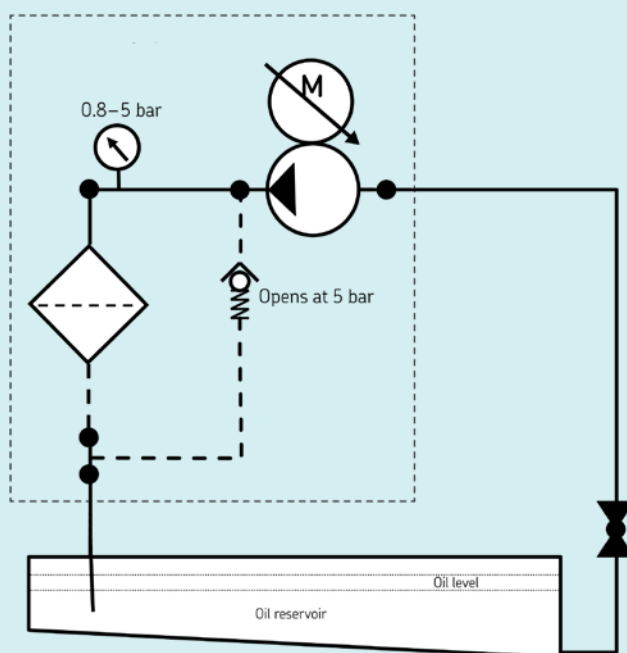

## Technical specification

Figure 2

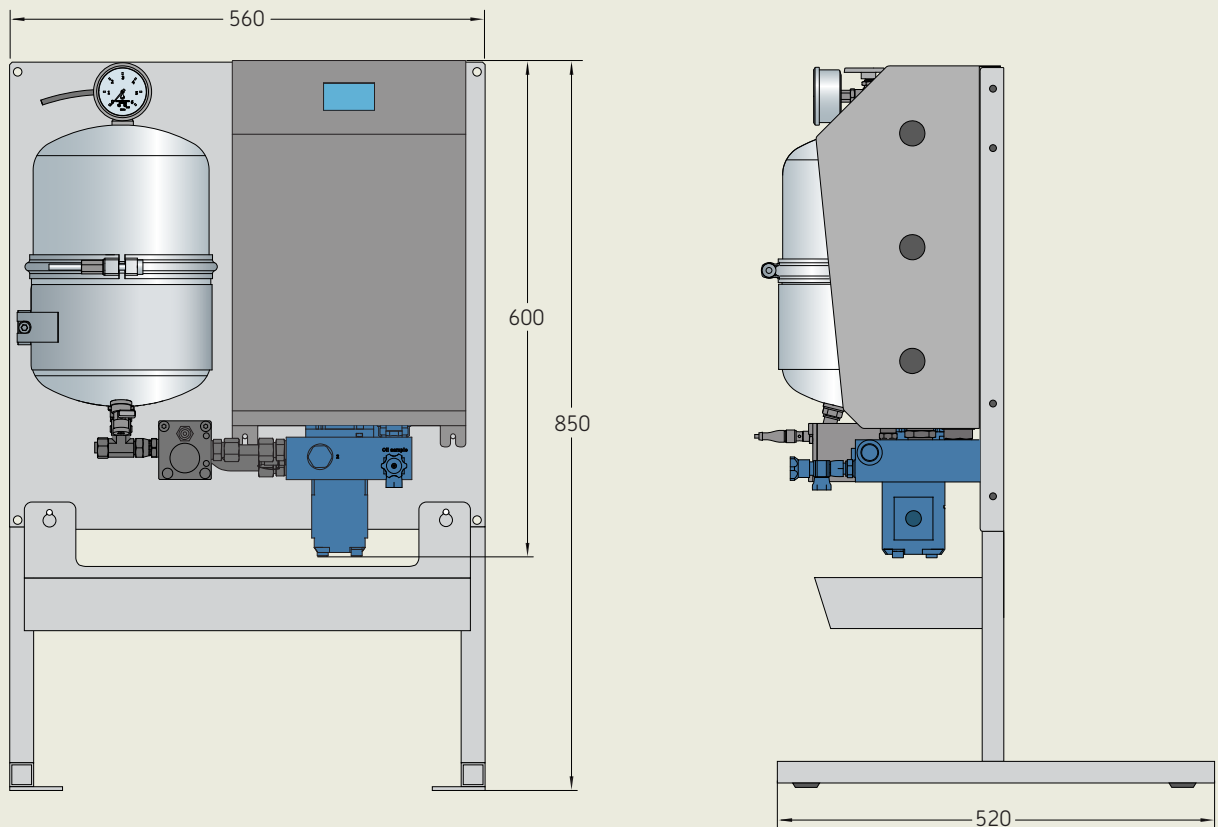

[skf.com](https://www.skf.com)

© SKF and RECONDOIL are registered trademarks of the SKF Group.

© SKF Group 2022  
The contents of this publication are the copyright of the publisher and may not be reproduced (even extracts) unless prior written permission is granted. Every care has been taken to ensure the accuracy of the information contained in this publication but no liability can be accepted for any loss or damage whether direct, indirect or consequential arising out of the use of the information contained herein.

PUB LS/P8 19315/1 EN · April 2022